



**AV-30-C**

**Installation Manual**



© 2020 - 2022 uAvionix Corporation. All rights reserved.

uAvionix Corporation

Bigfork, MT

[www.uavionix.com](http://www.uavionix.com)

[support@uavionix.com](mailto:support@uavionix.com)

Except as expressly provided herein, no part of this guide may be reproduced, transmitted, disseminated, downloaded, or stored in any storage medium, for any purpose without the express written permission of uAvionix. uAvionix grants permissions to download a single copy of this guide onto an electronic storage medium to be viewed for personal use, provided that the complete text of this copyright notice is retained. Unauthorized commercial distribution of this manual or any revision hereto is strictly prohibited.

uAvionix® and Ping® are registered trademarks of uAvionix Corporation and may not be used without express permission of uAvionix.

AV-30, AV-30-E, and AV-30-C, BeaconX, tailBeaconX, and skyBeaconX are trademarks of uAvionix Corporation and may not be used without express permission of uAvionix.

Patents [www.uavionix.com/patents](http://www.uavionix.com/patents)

# 1 Revision History

Revision	Date	Comments
A	4/24/2020	Initial release
B	7/13/2020	Added installation log-book entry requirement. Added method to determine proper screw length. Highlighted primary functions. Added items included in the ICA. Added startup time and AoA reference per MOPS requirement. Added reference to CFR 23.1321.
C	8/10/2020	Added reference to AoA operation in inverted flight and operation in excess of G limits. Added reference to utilize wire type in accordance with AC 43.13-1B.
D	6/3/2021	Updated Top Level Assembly references.
E	9/2/2021	Software update to 2.1.2 Added Definition of Acronyms & Terms section Added requirement for pitot / static connection Add vibration check to System Checkout
F	12/3/2021	Software update to 2.1.4 Update mounting screw length guidance Add transponder control
G	5/10/2022	Update Installation Limitations Update battery guidance Update trim guidance Update mislabeled note on DG wiring diagram

## 2 Warnings / Disclaimers

All device operational procedures must be learned on the ground.

uAvionix is not liable for damages arising from the use or misuse of this product.

This equipment is classified by the United States Department of Commerce's Bureau of Industry and Security (BIS) as Export Control Classification Number (ECCN) 7A994.

These items are controlled by the U.S. Government and authorized for export only to the country of ultimate destination for use by the ultimate consignee or end-user(s) herein identified. They may not be resold, transferred, or otherwise disposed of, to any other country or to any person other than the authorized ultimate consignee or end-user(s), either in their original form or after being incorporated into other items, without first obtaining approval from the U.S. government or as otherwise authorized by U.S. law and regulations.

### 3 Limited Warranty

uAvionix products are warranted to be free from defects in material and workmanship for two years from the installation of AV-30-C on the aircraft. For the duration of the warranty period, uAvionix, at its sole option, will repair or replace any product which fails in normal use. Such repairs or replacement will be made at no charge to the customer for parts or labor, provided that the customer shall be responsible for any transportation cost.

Restrictions: This warranty does not apply to cosmetic damage, consumable parts, damage caused by accident, abuse, misuse, fire or flood, theft, damage caused by unauthorized servicing, or product that has been modified or altered.

Disclaimer of Warranty: IN NO EVENT, SHALL UAVIONIX BE LIABLE FOR ANY INCIDENTAL, SPECIAL, INDIRECT OR CONSEQUENTIAL DAMAGES, WHETHER RESULTING FROM THE USE, MISUSE, OR INABILITY TO USE THE PRODUCT OR FROM DEFECTS IN THE PRODUCT. SOME STATES DO NOT ALLOW THE EXCLUSION OF INCIDENTAL OR CONSEQUENTIAL DAMAGES, SO THE ABOVE LIMITATIONS MAY NOT APPLY TO YOU.

Warranty Service: Warranty repair service shall be provided directly by uAvionix. Proof of purchase for the product from uAvionix or authorized reseller is required to obtain and better expedite warranty service.

Please email or call uAvionix support with a description of the problem you are experiencing. Also, please provide the model, serial number, shipping address and a daytime contact number.

You will be promptly contacted with further troubleshooting steps or return instructions. It is recommended to use a shipping method with tracking and insurance.

## 4 Table of Contents

1	Revision History .....	3
2	Warnings / Disclaimers.....	4
3	Limited Warranty .....	5
4	Table of Contents .....	6
5	Introduction .....	9
5.1	Purpose .....	9
5.2	Definition of Acronyms & Terms.....	9
6	AV-30-C System Information .....	10
6.1	System Description.....	10
6.2	System Functions .....	12
7	Certification .....	14
7.1	Mechanical Instrument Replacement.....	15
7.2	Non-Required Instrument Addition.....	15
7.3	Vacuum System Removal.....	15
7.4	Applicable Performance Standards.....	16
8	Installation Limitations .....	17
8.1	Installation Approval Limitations.....	17
9	Installation Locations & Operating Modes .....	18
9.1	Installation Locations .....	18
9.2	Operating Mode Configuration .....	19
10	Functionality and Required Interfaces .....	20
10.1	Aircraft Systems Connections .....	20
10.2	Feature Matrix.....	21
10.2.1	Power Input (Required) .....	22
10.2.2	Pitot and Static Interfaces (Required) .....	22
10.2.3	Outside Air Temp Input (Optional) .....	22
10.2.4	Audio Output (Optional).....	23
10.2.5	GPS Interface (Optional) .....	23
10.2.6	Internal Magnetometer (Optional).....	24
10.2.7	Transponder Control (Optional) .....	24
10.3	Internal Battery Operation .....	24
11	Equipment Installation.....	25
11.1	Overview.....	25

11.2	Supplied Components.....	26
11.3	Non-Supplied Components .....	26
11.4	Installation Records .....	26
11.5	Mechanical Drawing.....	27
11.6	Mounting Screw Length Restriction.....	28
11.7	Wiring Diagrams .....	29
11.8	Bonding Requirements .....	30
11.9	Unit Pinout .....	32
12	Optional Equipment Installation.....	33
12.1	Transponder (tailBeaconX) .....	33
12.1.1	Transponder Control.....	33
12.1.2	Transponder Testing with tailBeaconX .....	33
13	Setup & Configuration .....	34
13.1	Startup and Common Controls.....	34
13.2	Available Menus.....	35
14	Installation Menu .....	36
14.1	Mandatory Settings .....	39
14.1.1	Unit Function .....	39
14.1.2	Function Lock .....	39
14.1.3	Trim.....	39
14.1.4	V-Speeds .....	40
14.1.5	Display Units .....	40
14.1.6	Serial Inputs .....	40
14.1.7	AID Mode .....	41
14.1.8	Demo Mode.....	42
14.2	System Checkout.....	42
14.2.1	Alignment .....	42
14.2.2	Gyro Calibration .....	44
14.2.3	OAT Interface .....	46
14.2.4	GPS Navigator Interface.....	46
14.2.5	Vibration Check .....	47
14.2.6	EMC Checkout .....	49
15	Troubleshooting .....	51
16	Instructions for Continued Maintenance & Operation .....	52
17	Aircraft Flight Manual Supplements.....	52
18	Serial Interface Specification.....	53

19 Field Update Capability .....54



## 5 Introduction

### 5.1 Purpose

This installation manual applies to the following models:

- AV-30-C (Certified)

Unless otherwise specified, all information in this document applies to all product variants.

### 5.2 Definition of Acronyms & Terms

Acronym	Definition
AI	Attitude Indicator
AoA	Angle of Attack
BARO	Barometer; barometric
DALT	Density Altitude
DG	Directional Gyroscope
GPS	Global Positioning System
HIRF	High-Intensity Radiated Field
IAS	Indicated Airspeed
MFD	Multi-Function Display
OAT	Outside Air Temperature
TAS	True Airspeed
TSO	Technical Standard Order
V <sub>MC</sub>	Minimum controllable airspeed
V <sub>YSE</sub>	Best rate-of-climb speed with one engine inoperative
V <sub>2</sub>	Take-off safety speed. The lowest speed at which the aircraft complies with the handling criteria associated with the climb.
V <sub>T</sub>	Threshold crossing speed; target speed (after V <sub>2</sub> has been reached)
V <sub>SO</sub>	Minimum stall speed with gear and full flaps. The bottom end of the ASI white arc.
V <sub>S1</sub>	Minimum steady flight velocity while still controllable. The bottom end of the ASI green arc.
V <sub>FE</sub>	Maximum flap extended velocity. The top end of the ASI white arc.
V <sub>NO</sub>	Maximum normal operating velocity. The top end of the ASI green arc.
V <sub>NE</sub>	Maximum velocity in smooth air (never exceed). The red line at the top end of the ASI yellow arc.
V <sub>MC</sub>	Minimum control airspeed with the critical engine inoperative
V <sub>YSE</sub>	Speed for best rate of climb OEI (single engine)

## 6 AV-30-C System Information

This document provides instructions on the installation requirements for the uAvionix AV-30-C multi-mode instrument.

### 6.1 System Description

The uAvionix AV-30-C is a fully digital multi-mode instrument that mounts in the legacy 3-1/8" round instrument panel. It can be field configured as either an Attitude Indicator (AI) or a Directional Gyro (DG) indicator. It is fully self-contained with dual-precision inertial and pressure sensors and allows for a wide variety of pilot customization. Transponder control is available in both AI and DG modes.



*Figure 1 – AV-30-C Multi Mode AI/DG/Transponder – Basic Display*

When configured as an AI, primary attitude and slip are always displayed. The unused portions of the display area can be customized by the pilot to show a variety of textual and graphical data overlay fields. Three pages may be customized by the pilot while a fourth page presents a fully decluttered view of attitude and slip, while optionally presenting transponder controls.

When configured as a Directional Gyro (DG), direction of flight information is presented. The flight direction can be configured to be presented as a non-slaved heading or inertially stabilized GPS track when connected to an external GPS navigator. Multiple display presentations, including compass rose, GPS HSI, and GPS ARC views can be selected by the pilot. The unused portions of the display area can similarly be configured for a variety of textual data-overlays.

In all operating modes, the pilot may select from multiple visual styles which are intended to improve visual compatibility with legacy aircraft instrumentation and preserve the look-and-feel of older aircraft applications.

A wide variety of supplemental functions, including audio alerting, derived angle of attack presentation, g-load display, and more are provided. An internal, rechargeable battery allows for operation for a nominal 1 hour in the event of aircraft power loss in flight and 30 minutes minimum under all temperature conditions.

See *AV-30-C Pilots Guide UAV-1003946-001* for additional details.

## 6.2 System Functions

### Primary Functions:

- Primary Attitude (AI Mode)
- Primary Slip (AI Mode)
- Primary Direction of Flight Indication (DG Mode)

### Supplemental Functions:

- Indicated Airspeed
- Altitude
- V-Speeds
- Angle of Attack
- Vertical Trend
- Vertical Speed
- Set Altitude
- Heading
- Bus Voltage
- G Load
- Outside Air Temp
- True Airspeed
- Density Altitude
- GPS Navigator / Waypoint Data
- GPS Navigator Nav Data
- GPS Navigator Route Line
- Heading Bug
- Transponder Control (AI / DG Mode)

### Audio and Visual Alerting Functions:

- AoA Alerting
- G Limit Alerting
- Excessive Roll Alerting

### Misc. Functions:

- Internal Battery Operation
- Auto / Manual Brightness

Table 1 - System Specifications

<b>Electrical Attributes</b>	
Input Voltage Nominal	+10 to +32 VDC
Input Voltage Max	+60 VDC
Input Power Nominal	6 Watts (0.5 Amps @ 12VDC)
Input Power Max	12 Watts (1.0 Amps @ 12VDC)
Required Circuit Breaker	2 Amp
Operation on Battery	1 Hrs. Typ. @ 20°C / 30 Min Minimum @ -20C
<b>Physical Attributes</b>	
Mounting Configuration	3-1/8" Round Instrument Hole
Dimensions w/o Connector	3.38" x 3.38" x 1.6"
Weight	0.56 Lbs.
Electrical Connector	15 Pin Male D-Sub
Pneumatic Connectors	1/4" OD Quick Connect
Mounting	(4X) #6-32 Machine Screws
Case Material	Billet Aluminum
<b>Environmental</b>	
Ground Survival Low	-55°C
Operating Low	-20°C
Ground Survival High	+85°C
Operating High	+55°C
Altitude	25,000 Feet (maximum)
<b>Optical Characteristics</b>	
Diagonal Size	3" Circular
Contrast Ratio (Typical)	500
Brightness (Typical)	1000 cd/m <sup>2</sup>
Viewing Angle Left/Right	60°
Viewing Angle Up	45°
Viewing Angle Down	10°
Backlight Lifetime (Typical)	50,000 Hours

## 7 Certification

This installation manual provides mechanical and electrical information necessary to install the AV-30-C. The content of this manual assumes use by competent and qualified personnel using standard maintenance procedures in accordance with Title 14 of the Code of Federal Regulation (CFR) and other related accepted procedures.

The certification basis for the AV-30-C is 14 CFR Part 23, Amendment 23-61. Installation is approved as a Level A system and is robust to High Intensity Radiated Field (HIRF) and lightning levels applicable for both metallic and non-metallic aircraft.



The AV-30-C is approved for primary Attitude, Slip and Direction of Flight.

All other functionality is supplemental in nature and may not satisfy regulatory requirements for required instrumentation.



The installer must ensure that all installation limitations as defined in this document are observed.

The internal battery capacity has been tested and verified to provide 30 minutes of operational capacity (with reserve), and meets the requirements defined in CFR 23.1311(a)(5) and 23.1353(h), allowing independent operation from the primary electrical power system.

See §10.3 Internal Battery Operation for additional battery operational characteristics.



For aircraft capable of acrobatic flight, the AoA indication may become unreliable for operation in inverted flight and maneuvers exceeding  $\pm 8$  G.

## **7.1 Mechanical Instrument Replacement**

Approval is granted to replace legacy mechanical instrumentation as follows:

- Installation of the AV-30-C (Dedicated AI mode) as the primary source for attitude and slip. Installation replaces the existing stand-alone vacuum or electrically powered attitude indicator.
- Installation of the AV-30-C (Dedicated DG mode) as the primary source for direction-of-flight. Installation replaces the existing stand-alone vacuum or electrically powered non-slaved directional gyro indicator.

Note that when installed as a DG, a reversionary AI is available for display. This functionality is supplemental only and does not satisfy requirements for a backup or standby attitude, turn and slip, or turn coordinator.

## **7.2 Non-Required Instrument Addition**

Approval is granted to install the AV-30-C as a non-required instrument, augmenting existing required instrumentation. In this configuration, the AV-30-C must not replace an existing required instrument.

## **7.3 Vacuum System Removal**

The aircraft's vacuum system typically may be removed under a field approval process (FAA Form 337) if no other systems or equipment requires it. The AV-30-C installation approval does not address this alteration.

## 7.4 Applicable Performance Standards

The AV-30-C was designed to, and satisfies, the applicable performance requirements defined in the following design standards:

*Table 2 - Applicable Performance Standards*

<b>MOPS</b>	<b>Title</b>	<b>Category</b>
SAE AS8019	Airspeed Instruments	Type B
SAE AS392C	Altimeter, Pressure Actuated, Sensitive Type	Type I
SAE AS8005A	Standard Temperature Instruments	Class IIIc
SAE AS8034	Airborne Multipurpose Electronic Displays	N/A
RTCA DO-334	Attitude and Heading Reference Systems (AHRS)	A5 H9 T7
ASTM F3011-13	Angle Of Attack System	N/A
RTCA DO-347	Cert and Test for Small and Med LiPo Batteries	Medium Size



## 8 Installation Limitations

The following section provides the FAA approved installation limitations.

### 8.1 Installation Approval Limitations

This article meets the minimum performance and quality control standards required by an Approved Model List - Supplemental Type Certificate (AML-STC) and when installed on aircraft approved on the AML can be approved for return to service after installation.

If installation for an aircraft that is not listed on the AML, separate approval must be obtained. The following installation limitations apply:

- **Installation is restricted to CFR Part 23, Class I and II (gross take-off weight of no more than 6000 lbs) aircraft.**
- **Installation is restricted to aircraft with a 25,000-foot maximum (or less) ceiling limitation.**
- **Installation is restricted to aircraft with equal to or less than 300 knot Vne airspeed.**
- **Installation may not be performed as part of an integrated autopilot system including heading bug interface, attitude source or flight director display.**
- **Installation may not be performed as a replacement of a Horizontal Situational Awareness Indicator (HSI).**
- **In installations where the primary attitude indicator is being replaced, the existing airspeed and altimeter must remain in their factory locations.**
- **An electrical load analysis must be performed in association with the installation.**
- **Connection to the Audio interface is not allowed for IFR approved non-metallic aircraft due to indirect lightning protection limitations.**
- **A Wet compass must be installed in the aircraft.**

## 9 Installation Locations & Operating Modes

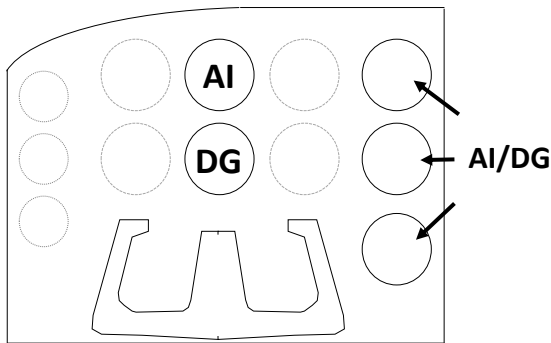

### 9.1 Installation Locations

The following figure shows a typical “six-pack” and one possible arrangement of instrument locations:



*Figure 2 – Mechanical Gauge Replacement*

Note that the physical arrangement in many aircraft varies from the configuration shown above. The AI/DG locations are examples of installation locations as a non-required instrument.

-  The existing mechanically based altimeter and airspeed indicator must remain in their factory locations for this installation configuration.
-  Installation as a pilot configurable AI/DG may not replace a primary instrument.

The replaced instruments may NOT be part of an autopilot or primary navigational display, such as an integrated autopilot system, autopilot heading bug source, attitude source, CDI, HSI or flight director display.

-  Reference CFR 23.1321 Arrangement and Visibility for additional FAA guidance on instrument installation location.

## 9.2 Operating Mode Configuration

The AV-30-C operating mode is configured during installation and can be set as follows:

- Unit locked as a dedicated Attitude Indicator (AI Mode)
- Unit locked as a dedicated Direction Indicator (DG Mode)
- Unit unlocked; can be toggled between AI and DG mode by the pilot.

Installations where dedicated functionality is required must have the associated setting configured in the setup procedures. This setting is mandatory and non-pilot accessible.

If the functionality is not locked, pressing and holding the rotary knob will toggle between AI and DG mode. This mode is only applicable for installation as a non-required instrument.



An AV-30-C that replaces the Attitude Indicator must have the operating mode locked as an AI.



An AV-30-C that replaces that Directional Gyro must have the operating mode locked as a DG.



An AV-30-C installed as a non-required indicator may be configured in any operating mode based on pilot preference.

Replaced instruments may NOT be part of an autopilot system such as the rate-of-turn source for an autopilot or display of flight director information from an autopilot.

# 10 Functionality and Required Interfaces

## 10.1 Aircraft Systems Connections

All aircraft systems connections are provided on the single 15-Pin D-sub connector and two quick-connect pneumatic fittings. Various interfaces are optional, and interface to some systems may require additional installation approval. Do not plug the pitot and static lines.

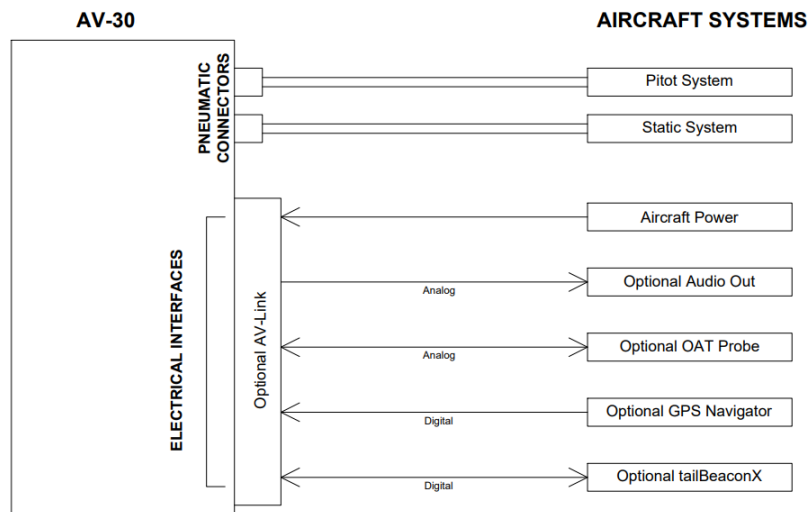

Figure 3 – AV-30-C Aircraft Systems Interfaces – AI Mode

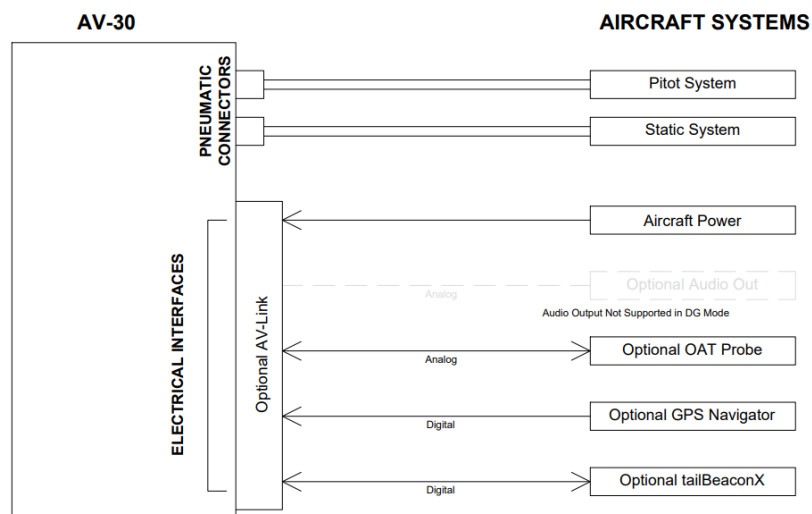

Figure 4 - AV-30-C Aircraft Systems Interfaces – DG Mode

## 10.2 Feature Matrix

The following matrix shows primary and supplemental data and any required external interface.

Table 3 - Feature Matrix

Feature	AI Mode	DG Mode	Required Interface
<b>Primary Attitude and Slip</b>			
Primary Attitude	✓	✗	Pitot / Static
Primary Slip	✓	✗	Pitot / Static
Reversionary Attitude / Slip	✗	✓	Pitot / Static
<b>Primary Direction of Flight Indication</b>			
Direction Tape (DG / GPS)	✓	✗	Pitot & static / GPS Navigator
Direction Rose (DG)	✗	✓	Pitot / Static
Direction Arc (GPS)	✗	✓	GPS Navigator
Direction HSI (GPS)	✗	✓	GPS Navigator
<b>Supplemental Data Overlays – Pilot Configurable (Textual or Graphical)</b>			
Indicated Airspeed (Textual)	✓	✗	Pitot / Static
V-Speeds (Graphical)	✓	✗	Pitot / Static
Baro Altitude (Textual)	✓	✗	Pitot / Static
Angle Of Attack (Graphical)	✓	✗	Pitot / Static
Vertical Trend (Graphical)	✓	✗	Pitot / Static
Vertical Speed (Textual)	✓	✗	Pitot / Static
Set Altitude (Textual)	✓	✗	None
Heading (Textual)	✓	✓	Pitot / Static
Bus Voltage (Textual)	✓	✓	None
G Load (Textual)	✓	✓	None
Outside Air Temp (Textual)	✓	✓	OAT Probe
True Airspeed (Textual)	✓	✓	Pitot / Static / OAT Probe
Density Altitude (Textual)	✓	✓	Pitot / Static / OAT Probe
<b>GPS Navigation / Waypoint Data</b>			
Textual Nav Data	✓	✓	GPS Navigator
Graphical Nav Data	✗	✓	GPS Navigator
<b>Heading Bug</b>			
Hdg Bug – Ref Only, no AP	✓	✓	None
<b>Audio and Visual Alerting</b>			
AoA Alerting	✓	✗	Pitot / Static
G Limit Alerting	✓	✗	None
Excessive Roll Alerting	✓	✗	None
<b>Misc.</b>			
Internal Battery Operation	✓	✓	Pitot / Static
Auto / Manual Brightness	✓	✓	None
Transponder Control	✓	✓	Transponder Serial / Pitot / Static

### **10.2.1 Power Input (Required)**

Power input is required in both AI and DG configurations and each unit has a dedicated circuit breaker. The power input is internally connected, and diode protected with the unit's internal battery via a processor-controlled switch. This architecture allows the unit to continue operation if external power fluctuates or is completely lost. Input range is compatible with both 12V and 24V aircraft.

Each AV-30-C must have a dedicated, properly labeled, pilot resettable circuit breaker as part of the installation. Power for the unit should be supplied from the main battery master relay. It is recommended to shield the power wire.

### **10.2.2 Pitot and Static Interfaces (Required)**

Pitot and static connections are required for DG and AI modes.

Airspeed, altitude, derived angle of attack (AoA), True Airspeed (TAS), Density Altitude (DALT), DG heading, and traffic altitude all require pitot and static connections as they are based on either altitude or airspeed measured from those connections.

When installed as a DG, the pitot and static connections must be connected for Outside Air Temperature (OAT), backup battery in flight, and DG heading aid. TAS and DALT are the only air-data related parameters that can be displayed when in DG mode.

### **10.2.3 Outside Air Temp Input (Optional)**

The optional outside air temperature interface requires a dedicated external analog probe. This port connection is compatible with the Davtron P/N C307PS (not supplied).

This is a differential two-wire current source based on the Analog Devices AD590KH component and supplies a current that corresponds to the ambient temperature.



If two displays are connected to the same probe, the current will be split between the two and incorrect readings will be shown by both.

The sensor reading must be trimmed during the installation process to compensate for probe-to-probe variations.

The OAT probe is automatically detected by the system, and when detected, allows temperature related parameters to be selected for display by the pilot.

If the OAT probe is not detected, display of these parameters will automatically be inhibited.

#### **10.2.4 Audio Output (Optional)**

The optional audio panel connection is a low-voltage analog output that is designed to connect directly to an audio panel (typically a non-switched or unswitched audio input). High power outputs capable of directly driving a cockpit speaker are not provided.

Other unswitched unmuted inputs can be used but they may need to be mixed with an existing audio source. Audio shields must be grounded only at audio panel to avoid ground loops. Contact audio manufacture for further instructions.

When installed as a DG, no audio alerting is supported, and this output should remain disconnected.



In non-metallic, IFR capable aircraft, this connection **MUST** remain disconnected due to lightning strike limitations.

#### **10.2.5 GPS Interface (Optional)**

The GPS interface is an optional RS-232 serial input that is compatible with the industry standard “Aviation” output provided by most panel mounted GPS units, and NMEA serial interfaces provided by most hand-held GPS units.

This is a text/binary protocol output by the GPS navigator that contains situational awareness information such as ground speed, track, distance to destination, cross track, etc., and is typically utilized by remote mapping/display products to provide additional pilot awareness.

This output does not provide IFR compliant lateral or vertical guidance, therefore all deviation related data presented is for VFR operations only.

The AV-30-C does no computations or operations on the data obtained from the GPS navigator, and simply displays the received data in a textual or graphical format as configured by the pilot.



This serial interface may be connected in parallel between multiple AV-30-C units and is supported in both AI and DG modes.

The supported protocols are contained in §18 - Serial Interface Specification.

### **10.2.6 Internal Magnetometer (Optional)**

The internal magnetometer, when available, is detected in software version 2.1.2 or later. It is currently disabled by configuration. Application of magnetometer data requires calibration before use. If magnetometer is desired and is not detected, please contact uAvionix technical support to discuss upgrade options.

### **10.2.7 Transponder Control (Optional)**

The AV-30-C has the option of being the control interface for select uAvionix transponders (including the BeaconX family). This provides pressure altitude, mode, squawk code, and IDENT information to the transponder, and displays status and annunciations from the transponder.



The transponder is not powered by the AV-30-C internal battery. Transponder operations will be unavailable during a power loss.

## **10.3 Internal Battery Operation**

The internal battery consists of a rechargeable battery system with automatic recharge, self-test, and power switching capability. The internal battery



capacity will provide approximately 1 hour of operation at standard temperatures and 30 minutes (minimum) of operational capacity over the operational temperature range.

When power is lost to the AV-30-C, the following will occur:

1. While AV-30-C is aligning, the unit will continue to battery mode if power is lost. Once aligned it will shut down.
2. If any button is pressed after power is lost, the AV-30-C will stay in battery mode.
3. If the AV-30-C senses airspeed or GPS groundspeed, it will stay in battery mode. Make sure that the caps have been removed from the back of the AV-30-C pitot and static ports.

If the AV-30-C needs to be shut down after removing power, press and hold the left and right buttons until the unit shuts down.

See the *AV-30-C Pilots Guide UAV-1003946-001* §10 Internal Battery Operation for additional operational information.

## **11 Equipment Installation**

### **11.1 Overview**

Installation consists of the following steps:

- Remove / relocate any legacy instrumentation
- Add or locate an appropriate power source / breaker
- Wire power and system interfaces as needed
- Mount the unit to the instrument panel with supplied screws
- Apply power and perform setup
- Connect pitot and static to both AI and DG. Perform leak check after installation.

## 11.2 Supplied Components

Table 4 - Supplied Components

Component	Part Number	Description
AV-30-C Unit	UAV-1003429-001	AV-30-C Unit
	UAV-1003429-002	AV-30-C Unit with Internal Magnetometer
AV-30-C Installation Kit	UAV-1004091-001	Installation Kit
AV-30-C Operating Software	UAV-1003494-003	AV-30-C Operating Software v2.1.4

## 11.3 Non-Supplied Components

Table 5 - Non-Supplied Components

Component	Description
Pitot / Static Tubing	Length as required
Pitot Static T's	Quantity as required
Circuit Breakers (2A)	One required for each instrument
OAT Probe	Davtron P/N C307PS
Power and Interconnect Wire	See AC 43.13-1B Chapter 11 § 7 for acceptable wire types

## 11.4 Installation Records

The date of installation should be recorded in the aircraft's log-book.

Entry should include instrument(s) being replaced (AI or DG, or both), or, if the installation is being performed as a non-required instrument.

Entry should also include a description of any optional connections made.

# 11.5 Mechanical Drawing

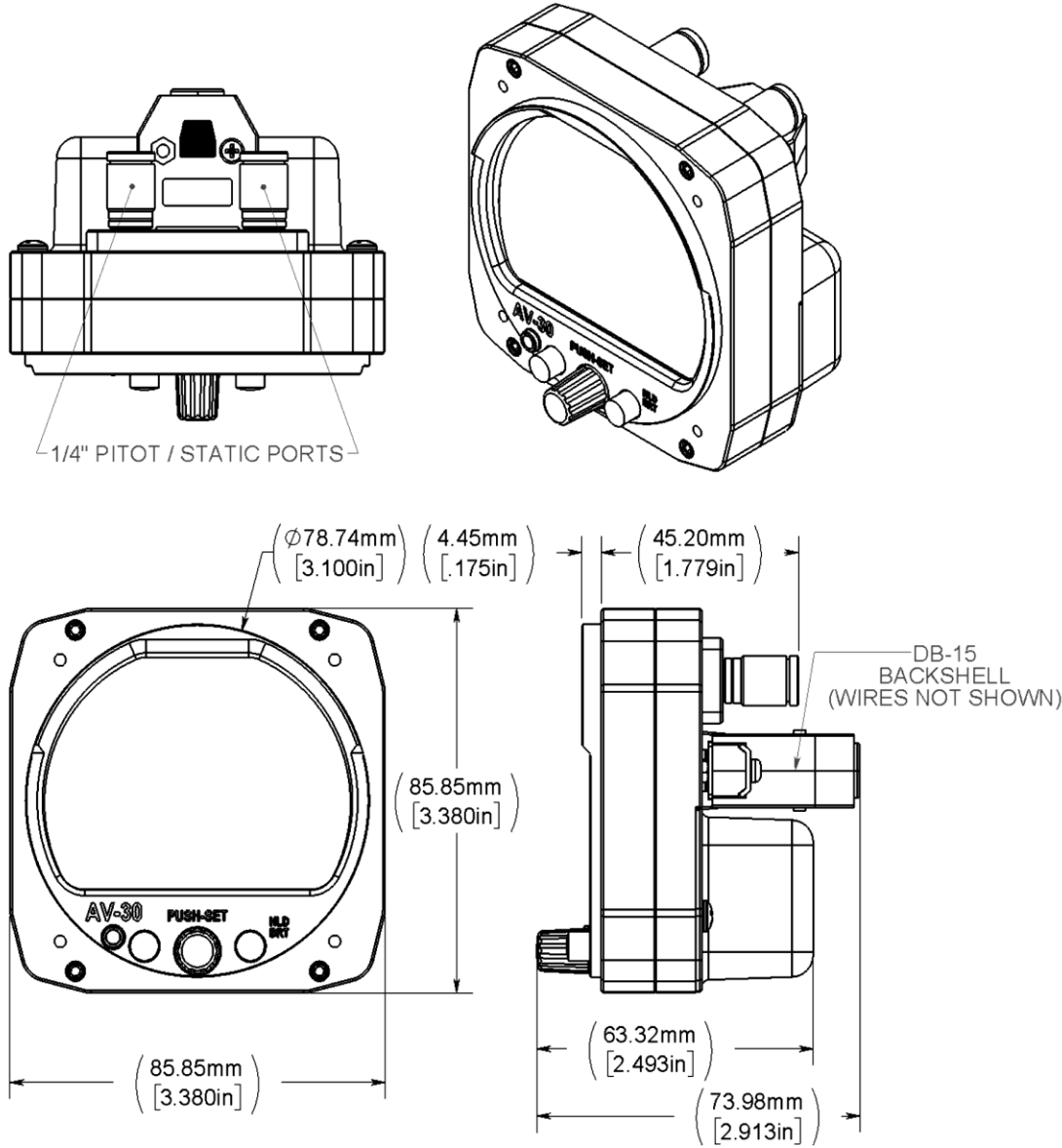

Figure 5 – Mechanical Drawing

## 11.6 Mounting Screw Length Restriction

The AV-30-C is fastened to the instrument panel with four 6-32 screws. The unit mounts from the rear of the instrument panel, with the screws being inserted from the front of the panel.



The four 6-32 Mounting screws **must** observe depth limits given the internal component design.



Torque screws to 6 (+/-1) inch-lbs. Do not over-torque or damage may occur.

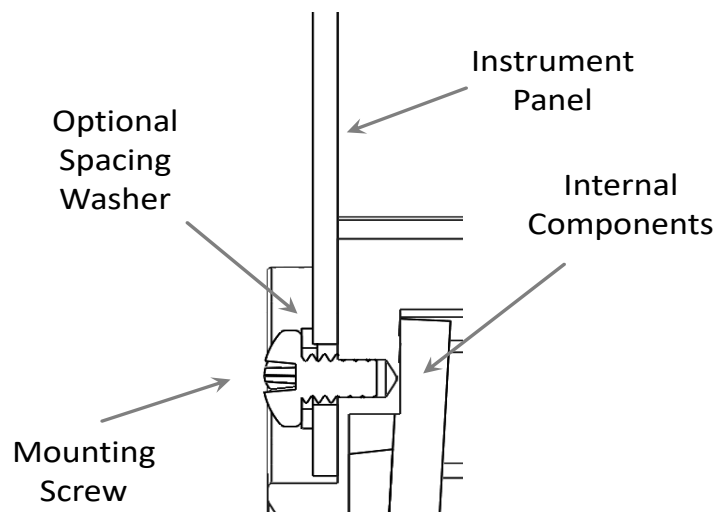

*Figure 6 – Mounting Screw Dept Limits*

Caution must be observed when mounting the AV-30-C. If too long a screw is used, damage to the unit can occur, and the unit may not be securely fastened to the panel. The installation kit contains multiple length screws to assist in compensating for different instrument panel thicknesses.

Correct screw length may be determined by inserting the supplied screw in the instrument panel (without the AV-30-C installed) and ensuring that either three or four full threads are exposed on the opposite side of the panel. Select alternate lengths as needed.

## 11.7 Wiring Diagrams

The AV-30-C performs different functions when installed as an AI or DG, and therefore wiring varies based on installation. Figure 7 and Figure 8 show connections for each configuration.

The primary difference is that the DG does not support audio alerting.

See AC 43.13-1B Chapter 11 § 7 for acceptable wire types for both power and interconnect purposes.

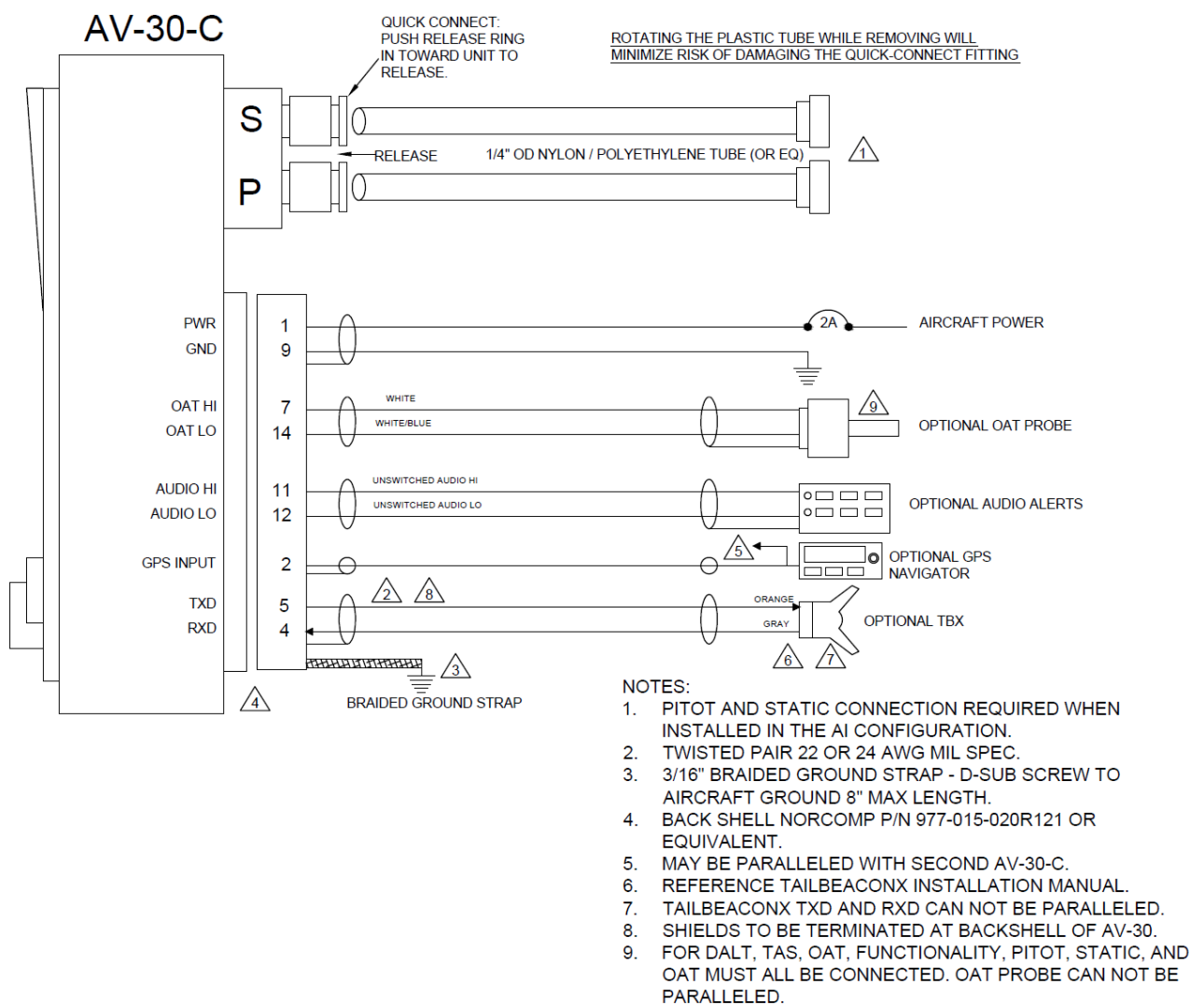

Figure 7 - Wiring Diagram - Attitude Indicator Position Installation

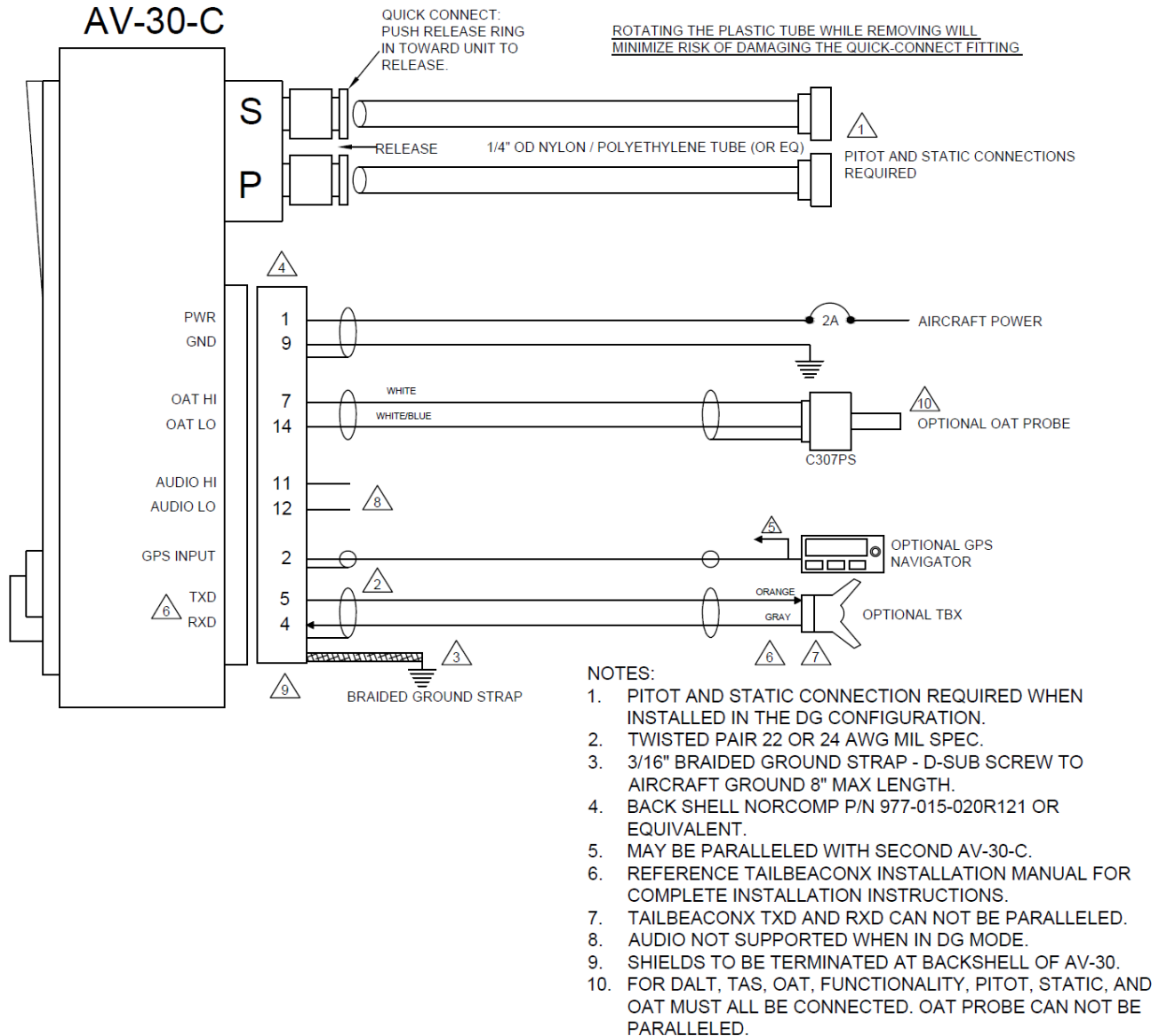

Figure 8 - Wiring Diagram - DG Position Installation

## 11.8 Bonding Requirements

The following figure shows the grounding requirements for the electrical connections. The two D-Sub screws are to be utilized for shield and ground strap connections.

The supplied ring terminal connectors are sized for these screws.

The ground braid strap is to be less than 8 inches in overall length and at least 3/16 width. Alpha Wire part number 1230 SV001 or equivalent.



Figure 9 - Ground Braid Strap - 8" or Less in Length

The exposed (non-shielded) portions of the interface cables AND the shield grounds are to remain less than 2.5 inches.

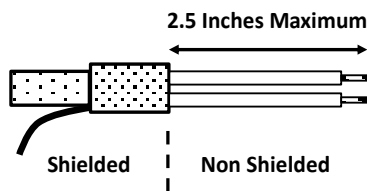

Figure 10 - Shielded Cable



The bond between the unit (measured at the D-sub screws) to the aircraft frame must be 2.5 milli-Ohms or less.

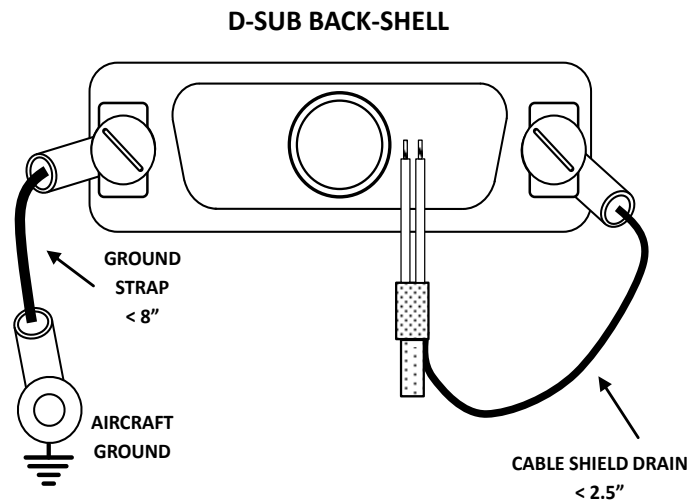

Figure 11 - Cable Shields and Ground Strap

## 11.9 Unit Pinout

Table 6 - Connector Pinout

Pin	Function	Type	Comment
1	Power	Power	+12 to +28 VDC
2	GPS Navigator	Input	GPS RS-232
3	Spare Serial	Output	Reserved - Do Not Connect
4	Serial 2	Input	Transponder RS-232
5	Serial 2	Output	Transponder RS-232
6	Spare Serial	Input	Reserved - Do Not Connect
7	OAT Supply	Output	White Probe Wire
8	MFG Serial	Input	Reserved - Do Not Connect
9	Ground	Power	Aircraft Ground
10	Aux Power Ret	Power	Reserved - Do Not Connect
11	Audio H	Output	Audio Alerts Hi
12	Audio L	Output	Audio Panel Lo
13	Aux Power Out	Power	Reserved - Do Not Connect
14	OAT Return	Input	White / Blue Probe Wire
15	MFG Serial	Output	Reserved – Do Not Connect

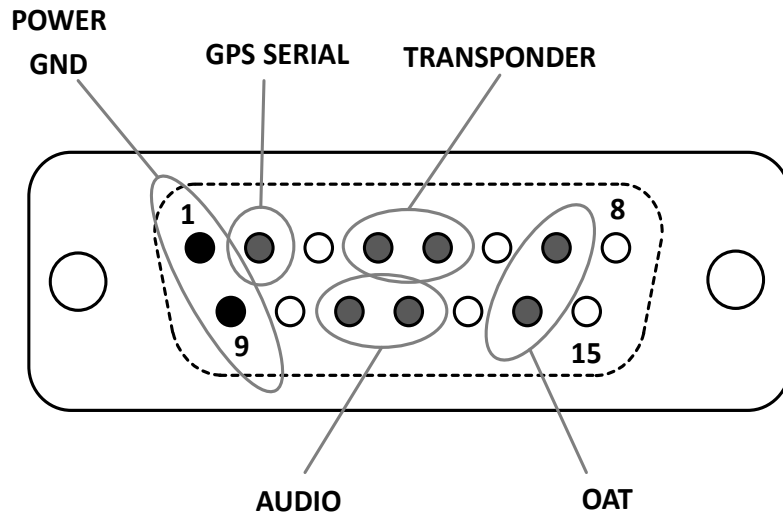

Figure 12 - Unit Connections – DB-15, Male (Rear Unit View)



## 12 Optional Equipment Installation

### 12.1 Transponder (tailBeaconX)



For complete installation guidance, see *tailBeaconX TSO User and Installation Guide UAV-1004270-001* and *tailBeaconX STC Installation Manual UAV-1003599-001*.



For operation of tailBeaconX using the AV-30-C, see *AV-30-C Pilot's Guide UAV-1003946-001*.

tailBeaconX is a complete Mode S Extended Squitter (ES) ADS-B OUT transponder, integrated with an internal SBAS/WAAS GPS and all necessary antennas into an LED rear position light. tailBeaconX is designed to meet the transponder and ADS-B requirements for operating in controlled airspace worldwide, while minimizing installation costs.

tailBeaconX can optionally provide GPS information to the AV-30-C, including magnetic track and groundspeed.

#### 12.1.1 Transponder Control

Transponder controls are enabled by selecting “BEACON X” on the “SERIAL 2” installation menu. See *AV-30-C Pilot's Guide UAV-1003946-001* for transponder control information.

#### 12.1.2 Transponder Testing with tailBeaconX

- Set tailBeaconX in STBY mode using the AV-30-C.
- Connect to tailBeaconX Wi-Fi and open the mobile installation application on your mobile device (uAvionix SkyBeacon Installer).
- On the Monitor tab, scroll to the bottom of the page and select “Enable Ground Test Mode”.
- Set tailBeaconX in ALT mode using the AV-30-C.
- tailBeaconX will now respond to All-Calls on transponder test sets.
- When test is complete, cycle power.

# 13 Setup & Configuration

## 13.1 Startup and Common Controls

When powered on, the initial splash screen presents the company logo, unit model number, and the currently installed software version.



Figure 13 - Splash Screen

Operation in both AI and DG modes share common user interface controls as follows:

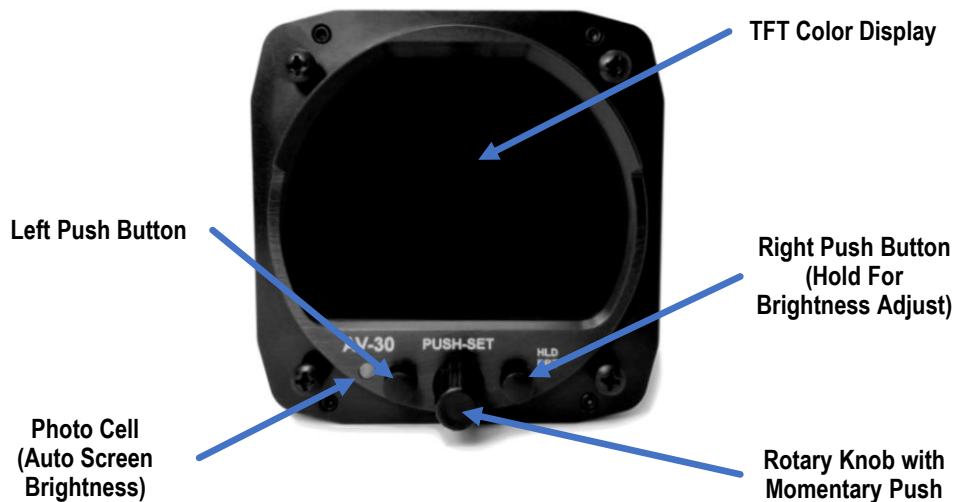

Figure 14 - Common User Interface Components

## 13.2 Available Menus

Setup and configuration menus are divided into three categories as follows:

- Edit Fields Menu (Pilot accessible)
- Setup Menu (Pilot accessible)
- Install Menu (Non-Pilot accessible)

The edit fields menu allows the pilot to configure the display to show the various supplemental parameters in the desired locations. Details of this are covered in *AV-30-C Pilots Guide UAV-1003946-001* and not addressed here.

The Setup Menu allows the pilot to set various configurations and alerting limits as desired for the type of operations being performed. These are also covered in the Pilot's Guide referenced above.

The installer may wish to pre-configure some or all these settings for the pilot, but the default settings are acceptable.



The Install Menu is for settings that are not normally required to be adjusted during flight. The installer must review and set these according to the installation configuration.

## 14 Installation Menu

The installation menu is used to configure the AV-30-C after installation and should only be accessed on the ground and changed by the installer.

To enable access the installation menu, ensure the unit is completely turned off. Press and hold the main control knob in while power is applied.



*Figure 15 - Installation Menu Access*

Keep the knob pressed until the startup logo has appeared. The installation menu will now be enabled for access but will not automatically appear on the screen.

Ensure the unit is in AI or DG mode; select the mode by pressing and holding the center button until the mode display changes. When in AI or DG mode, press and release the left MENU button three times until “INSTALL / ROT TO SEL” appears. The sequence of fields displayed is shown in Figure 16.



Figure 16 - Installation Menu Access

Rotating the knob left and right will access the various parameters that may be configured. Pressing the knob when the desired field is shown will allow the associated setting to be adjusted.

After adjustment, pressing the knob again will exit the editing mode but the installation menu will remain active.



Figure 17 - Exiting Edit Mode

Pressing DONE or a lack of user input for 30 seconds will exit the installation menu and return to the primary screen.



Figure 18 - Setup Done / Exit Option

Table 7 - Installation Menu Setting

Label	Description	Values
UNIT FUNCTION	Unit functionality	Set to default mode: AI* or DG
FUNCTION LOCK	Functionality Lock	If locked, pilot may not change unit function
PITCH TRIM <sup>[AI]</sup>	Pitch trim	Trim as needed: $\pm 20$ Degrees (0*)
ROLL TRIM <sup>[AI]</sup>	Roll trim	Trim as needed: $\pm 5$ Degrees (0*)
SLIP TRIM <sup>[AI]</sup>	Slip trim	Trim as needed: $\pm 5$ Degrees (0*)
OAT TRIM <sup>[AI]</sup>	OAT probe trim	Trim as needed: $\pm 200$ (Unitless) (0*)
IAS TRIM <sup>[AI]</sup>	IAS trim	Trim as needed: $\pm 50$ KTS or MPH (0*)
ALT TRIM <sup>[AI]</sup>	Barometric altitude trim	Trim as needed: $\pm 500$ Feet
IAS UNITS <sup>[AI]</sup>	IAS display units	Knots* (KTS) or Miles Per Hour (MPH)
IAS VSO <sup>[AI]</sup>	Stalling speed in landing configuration	Set to match limits: 40 to 300 knots (50*)
IAS VS1 <sup>[AI]</sup>	Stalling speed in a specific configuration	Set to match limits: 40 to 300 knots (60*)
IAS VFE <sup>[AI]</sup>	Maximum flap extended speed	Set to match limits: 40 to 300 knots (100*)
IAS VNO <sup>[AI]</sup>	Maximum structural cruising speed	Set to match limits: 40 to 300 knots (150*)
IAS VNE <sup>[AI]</sup>	Never exceed speed	Set to match limits: 40 to 300 knots (175*)
IAS VMC <sup>[AI]</sup>	Minimum control airspeed with the critical engine inoperative	Set to match limits: 40 to 300 knots or disabled*
IAS VYSE <sup>[AI]</sup>	Speed for best rate of climb OEI (single engine)	Set to match limits: 40 to 300 knots or disabled*
BARO UNITS <sup>[AI]</sup>	Altimeter barometric units	Inches of Mercury* (INHG), Millibars (MB)
TEMP UNITS <sup>[AI]</sup>	OAT units	Celsius* (C) or Fahrenheit (F)
GPS NAV SRC	Serial GPS format	NONE*, AV1 9600, NMEA1 4800, NMEA1 9600, BEACON X
SERIAL 2	Reserved	NONE*, BEACON X
SERIAL 3	Reserved	NONE*
AID MODE	AHRS aiding mode	NONE*, MAG1, MAG2 – MAGx only available for units with magnetometer
VIBE MONITOR	Vibration monitor	Push to view
GYRO CAL	Calibrates aircraft gyros	Perform at installation or software update
MAG CAL	Calibrates internal magnetometer	Perform in-flight calibration after installation – only available for units with magnetometer
DEMO MODE	Demo mode	DISABLED*, MODE 1, MODE 2
SW PART NUM	Software part number	For reference
SW VERSION	Software version	For reference
SW CHECKSUM	Software checksum	For reference
SW CERT	Software certification	For reference

<sup>[AI]</sup> Available when Install Menu accessed through AI mode only

\* Initial factory value

## 14.1 Mandatory Settings

The following settings are mandatory for each installation.

### 14.1.1 Unit Function

- Set to AI if installation is replacing an existing Attitude Indicator.
- Set to DG if installation is replacing an existing Direction Indicator.
- Set to either when installation is as a non-required instrument. In this mode, this setting is the initial default operating mode if the function lock below is not set to locked. With this setting, pilot may toggle mode.

### 14.1.2 Function Lock

Enable function lock for primary AI and DG installations. This prevents the pilot from toggling the operating mode.

Installation on a non-required instrument may be locked or not locked, based on owner preferences. Pressing and holding the center knob when functionality is not locked will toggle between AI, DG, and MFD modes.

### 14.1.3 Trim

Access to trim settings for various values can be accomplished by accessing the Install menu while in AI mode only.

- Set Pitch, Roll and Slip Trim to accommodate any mounting variations.
  - Accurate pitch, roll and slip trim is important to ensure optimal performance
- Set IAS and Altitude Trims to match existing instrumentation or test equipment as needed.



IAS and Altitude are factory calibrated to ensure accuracy.

Depending on installation or correspondence requirements, or to accommodate sensor aging, trimming of both functions can be achieved.

- Trim the OAT values to match that of a secondary temperature source such as ATIS.

#### 14.1.4 V-Speeds

Set each of the V-Speeds to the values that correspond to the installation aircraft in knots.

#### 14.1.5 Display Units

- Set the IAS units to match that of the existing airspeed indicator.
- Set the Baro units to match that of the existing altimeter.
- Set OAT units to owner / pilot preference.

#### 14.1.6 Serial Inputs

- GPS NAV SRC

Most handhelds are NMEA outputs while most panel mounted navigators are Aviation format. When allowed by installation, a tailBeaconX can also supply GPS input by selecting BEACON X.

Set to the corresponding GPS navigator input type.

Value	GPS Source
NONE	No source available
AV1 9600	Aviation format (9600 bps)
NMEA1 4800	NMEA format (4800 bps)
NMEA1 9600	NMEA format (9600 bps)
BEACON X	tailBeaconX (BEACON X must be selected for SERIAL 2)

- SERIAL 2

Set SERIAL 2 to NONE unless otherwise authorized.

Value	Serial 2 Source
NONE	No source available
BEACON X	tailBeaconX – Only enable when authorized by separate approval



APA MINI	Autopilot adapter – Do Not Enable unless authorized by follow-on approval
----------	---

- SERIAL 3

Set SERIAL 3 to NONE unless otherwise authorized.

Value	Serial 3 Source
NONE	No source available
AVLINK	AV-Link – Do Not Enable unless authorized by follow-on approval

#### 14.1.7 AID Mode

Set AID MODE to NONE.

There are up to 3 options for the AID MODE, which controls the method of aiding the AHRS DG functionality.

Value	AHRS Aiding Source
NONE	None used
MAG1	Internal magnetometer provides correction data to DG – Do Not Enable unless authorized by follow-on approval
MAG2	Internal magnetometer provides correction data to DG and aiding to core AHRS algorithm – Do Not Enable unless authorized by follow-on approval

Rotate the center knob until “AID MODE” is displayed. If the internal magnetometer is available (P/N UAV-1003429-002) then you will have a choice of NONE, MAG1, and MAG2. If the internal magnetometer is not found, only “NONE” will be displayed.

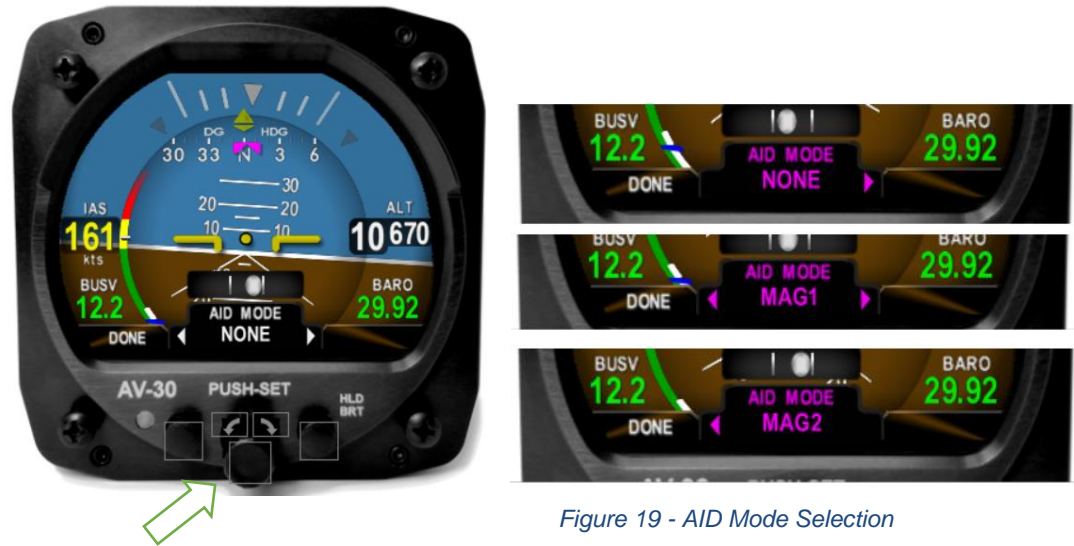

Figure 19 - AID Mode Selection

Press the center knob and rotate to select your choice of Magnetometer aiding and then press the center button to confirm your choice.

#### 14.1.8 Demo Mode

Set Demo Mode to DISABLED.

### 14.2 System Checkout

The following procedures must be performed prior to returning the aircraft to service.

#### 14.2.1 Alignment

During initial startup, the ALIGN annunciator should be presented and flash. This indicates internal sensor stabilization is occurring. During the alignment, do not move the aircraft.

This should extinguish within 3 minutes, at which point valid attitude or direction indication is displayed.

If power is removed from the unit while it is still aligning the unit will go to battery mode until it has completed the alignment process.



*Figure 20 - Aligning Annunciator*

If the indicator is not extinguished within 3 minutes, reference the troubleshooting section of this document for additional information.

## 14.2.2 Gyro Calibration

As units age or experience unusual conditions, the precision gyroscopic sensors may need to be re-calibrated. This can be accomplished in the field using the procedure noted here. At least 15 minutes of warmup is required before performing the AV-30-C gyro calibration.

1. Before applying power, press and hold the center rotary knob and apply power. As the splash screen appears, check that a minimum version of 2.1.2 is displayed. Gyro Calibration must be completed on all units with software version 2.1.2 or later.
2. With the AV-30-C in the AI mode, enter the “Install Menu” page by pressing and releasing the left button repeatedly until the 3<sup>rd</sup> menu is displayed. The aircraft must be on the ground with no movement.



Figure 21 - Install Mode Selection

3. **It is critical to ensure the aircraft is completely motionless** and on the ground during the next several steps. The aircraft should be in a hangar and must not be affected by wind or other sources of aircraft movement. **Do not leave the aircraft during the countdown.**
4. Rotate the “Install Menu” to “GYRO CAL” and press the center button to choose calibration. If sufficient warmup time has not elapsed, a “Not ready to calibrate” message and countdown will be indicated. Otherwise, initiate calibration by pressing the right button.



Figure 22 - Gyro Calibration Selection

5. “Calibration in progress” will be displayed with a percentage complete.



Figure 23 - Gyro Calibration Procedure

6. AV-30-C will indicate “Calibration successfully completed / Press DONE”.

Press the left button under “DONE” and the calibration will be complete. If an error is shown, repeat the calibration process.

### 14.2.3 OAT Interface

If an Outside Air Temperature (OAT) probe is connected, utilize the display customization guidance provided in the Pilot's Guide to configure the display to show OAT in at least one textual display field.



Figure 24 - OAT Indicator

Note that OAT calibration is performed in the Setup procedures. This step only ensures that the OAT probe is detected properly.

### 14.2.4 GPS Navigator Interface

If a GPS Navigator is connected, utilize the display customization guidance provided in the Pilot's Guide to configure the display to show GPS navigational data in at least one textual display field.

The image below shows a typical configuration that the pilot may setup.



Figure 25 - GPS Data Elements

On the GPS navigator, set a destination waypoint and initiate a direct-to sequence. Note that not all navigators will output serial data until a waypoint has been selected and navigation initiated.

#### 14.2.5 Vibration Check

Prior to flight, a vibration check **must** be completed. The vibration check helps ensure the vibration characteristics of the aircraft and installation are suitable for use. The check procedure is performed during an engine run-up.

1. Before applying power to the AV-30-C, press and hold the center rotary knob and apply power. As the splash screen appears, check that a minimum version of 2.1.2 is displayed.
2. Enter the “Install Menu” page by pressing and releasing the left button repeatedly until the 3<sup>rd</sup> menu is displayed.
3. Rotate to “VIBE MONITOR” and press the center button.



Figure 26 - Vibe Monitor Selection

4. The Vibration Monitor will display current and peak values for the Accelerometer and Gyroscope.



Figure 27 - Vibe Monitor Operation

5. Perform an engine run-up, slowly increase engine power from idle to full and back to idle.
6. Record the peak values observed for both the Accelerometer and Gyroscope.

Peak values for the Accelerometer should not exceed **110**, and for the Gyroscope should not exceed **40**. If excessive values are observed, vibration must be mitigated to ensure expected performance. Consider the following:

- Ensure proper propeller balance. Perform dynamic propeller balancing.
- Replace worn engine mounts and address causes of high engine vibration.
- Ensure the AV-30-C is not mounted in a location subject to high vibration. This can often be detected by placing your hand on various locations in the panel, and can be caused by poorly supported panel regions, adjacent equipment, or proximity to engine structure.
- On isolated panels, replace the grommets; concurrently, ensure isolated panels have a ground strap.
- Ensure all mounting hardware is firmly attached.
- Check for rub marks on the AV-30-C case.
- Ensure connectors are firmly attached, and all cabling is firmly supported and not causing undue flex. The cabling must not be hitting or close to a moving surface (e.g. control yoke).



## 14.2.6 EMC Checkout

An EMC check should be performed after the AV-30-C installation is complete. The EMC check verifies that the newly installed equipment is not producing interference to other avionics and that the existing avionics are not producing interference to the AV-30-C. The testing assumes the AV-30-C operational check has been completed and that the installed avionics to be tested are all in working condition.

1. Power on all avionics except the AV-30-C.
2. Verify all existing avionics are functioning properly. Some systems may require startup messages to be acknowledged/cleared to verify proper function.
3. After confirming all existing avionics are functioning properly, power off all existing equipment.
4. Power on the AV-30-C and perform the following tests as they apply to the existing aircraft equipment.
5. Observe load shedding procedures as appropriate for the aircraft during testing to ensure adequate power to complete the testing while maintaining enough reserve to support pre-flight and engine start.

### VHF COM RADIOS

Verify AV-30-C operates without interference from the VHF COM operation.

1. Power on the VHF COM radio.
2. Transmit on a low, medium, and high frequency. Unused frequencies are recommended for this test. Example frequencies: 118.0, 126.0, and 135.0 Mhz.
3. During each transmission verify the AV-30-C continues to operate properly.

Verify each radio operates without interference from the AV-30-C.

1. Monitor a local frequency and verify there are no unintended squelch breaks or other tones that would interfere with communications.
2. Monitor a remote (distant) frequency and verify there are no unintended squelch breaks or other tones that would interfere with communications.

3. Monitor an unused frequency and verify there are no unintended squelch breaks or other tones that would interfere with communications.

### VHF NAV RADIOS

Verify VHF NAV operates without interference from the AV-30-C.

1. Power on the VHF NAV radio.
2. Monitor a local, remote, and unused frequency.
3. Verify there are no misleading navigation indications during the monitoring of each frequency.
4. Verify audible station ID and that the station is clear of audio interference that would prevent identification.

### ADDITIONAL AVIONICS

Additional Avionics should be tested according to the manufacturer EMC/EMI test procedures. This testing assumes the existing equipment is functional and operating correctly at time of testing. The following summarizes a typical EMC test.

1. Operate the AV-30-C.
2. Operate the existing installed avionics according to manufacturer instructions. If capable, utilize the device transmit and receive functions through a range of values.
3. Verify no errors, warnings, or unexpected operation is observed on the AV-30-C during operation of the installed avionics.
4. Verify no errors, warnings, or unexpected operation is observed on the installed avionics during operation of the AV-30-C.

## 15 Troubleshooting

The following steps are to aid in identifying installation or unit performance related issues:

Table 8 - Troubleshooting

Issue	Possible Reason
<b>Power</b>	
Unit does not power-on	Check associated breakers
	Ensure aircraft battery is greater than 10 VDC
	Check wiring and pinouts
Unit will not shut off, even if power is removed	Ensure no pitot or static blockage or line kinks are present (locking pressure and airspeed indication over 40 knots)
<b>Stabilization</b>	
Unit will not stabilize and aligning annunciator remains on	Return to factory for service if unit does not align within 3 minutes of power-on
DG drifts more than 30 degrees per hour	Make sure you are running the newest software
	Complete Gyro Cal
<b>Battery</b>	
Battery indication shows FAIL	Contact uAvionix support
<b>Trim</b>	
Roll, Pitch or Slip show small but constant error	Ensure unit is level in panel (using a bubble level or similar)
	Set trim adjustment in Installation menu. See Installation Manual for instructions
Airspeed or Altitude shows small but constant error	Set trim adjustment in Installation menu. See Installation Manual for instructions
<b>Interface</b>	
GPS information is expected but does not show up in data overlays	Check GPS input is configured to match the connected GPS serial data type and speed
	Set direction indication to GPS TRK
“NO DATA” is shown	Check interface cables and pinouts
“NO GPS” is shown	Check GPS input is configured to match the connected GPS serial data type and speed
<b>Alerts</b>	
Audio alerts not heard over the audio system	Check wiring and ensure alerts are enabled in the Setup menu
	Ensure unswitched input is available on the audio panel
	Verify volume setting is sufficiently high in the Setup menu
Nuisance alerts are generated	Ensure alerting limits are configured as desired in the Setup menu
	Disable any undesired alerting features in the Setup Menus.

## **16 Instructions for Continued Maintenance & Operation**

See *AV-30-C Instructions for Continued Airworthiness UAV-1004045-001* (ICA) for replacement, inspection requirements and procedures.

The ICA addresses the following aspects of continued airworthiness:

- Visual Inspection Procedure
- Altimeter Test and Calibration
- Battery Test and Replacement Procedure

## **17 Aircraft Flight Manual Supplements**

See *AV-30-C Flight Manual Supplement UAV-1004044-001* for normal, emergency and limitations as required by CFR §23.1581.

## 18 Serial Interface Specification

GPS serial input is compatible with the “Aviation” and NMEA serial protocols. Aviation protocol is 9600 Baud, No Parity, 8 Data Bits, 1 Stop bit. NMEA is either 4800 or 9600 Baud, No Parity, 8 Data Bits, 1 Stop Bit.

The packets received are as follows:

*Table 9 - GPS Serial Specification*

Parameter Name	Aviation Packet	NMEA Packet
GPS Track	“C” Packet	\$GPRMC, Field 8
GPS Ground Speed	“D” Packet	\$GPRMC, Field 7
Distance to Waypoint	“E” Packet	\$GPRMB, Field 10
Cross Track Error	“G” Packet	\$GPRMB, Field 2
Desired Track	“I” Packet	Computed
Waypoint ID	“K” Packet	\$GPRMB, Field 5
Bearing to Waypoint	“L” Packet	\$GPRMB, Field 11
Magnetic Variation	“Q” Packet	\$GPRMC, Field 10
AT Master Flag	“T” Packet, Flag 4	\$GPGGA, Field 6
Garmin Master Flag	“S” Packet, Flag 5	N/A

# 19 Field Update Capability

The unit software can be field updated. Updating requires an in-line harness and Windows based PC. Contact uAvionix support for additional information, or reference available Service Bulletins.

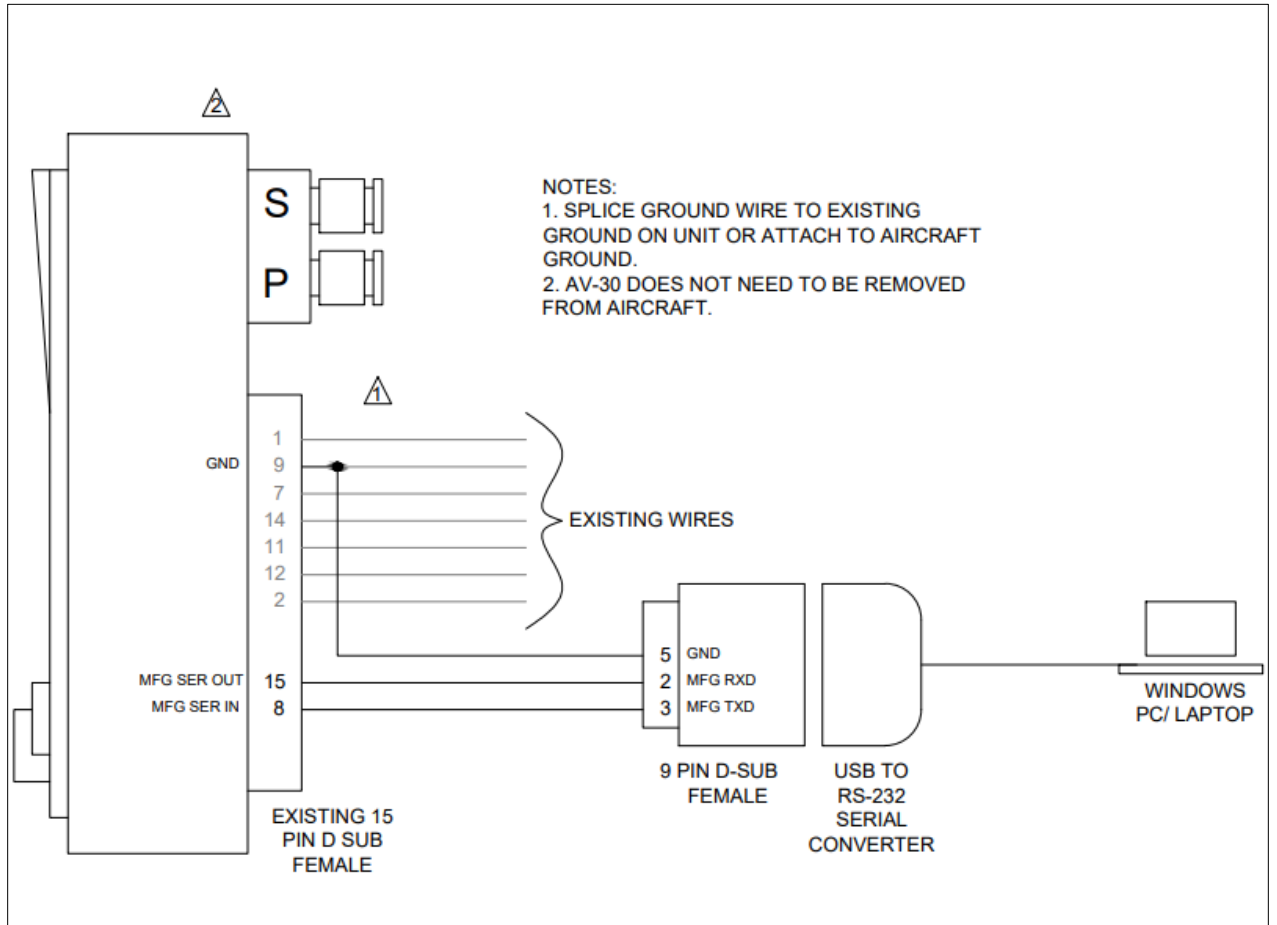

Figure 28 - Field Update Interface Diagram